

REVISIONS					
REV.	DATE	ECN #	DESCRIPTION	BY	APPROVED
1	2-4-08		WAS AS1151-XX3	CJT	JM
2	11/1/2018	HJ18-207	ADDED LOCKWASHER CALLOUT	TJF	LO

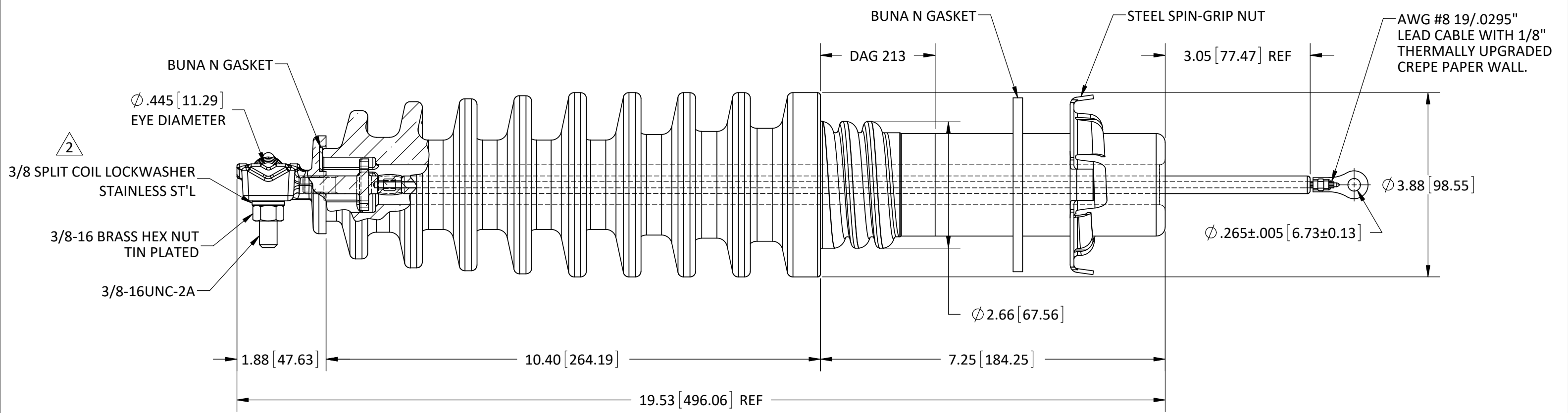
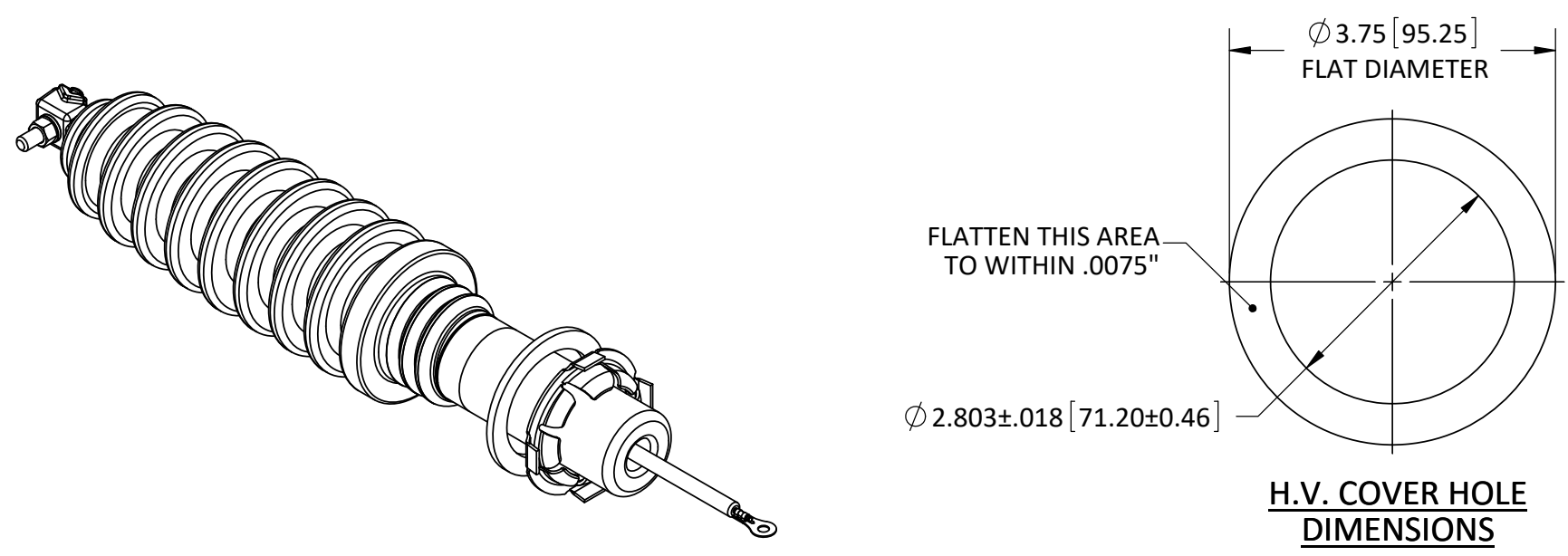

PORCELAIN NOTES:

1. WET PROCESS ELECTRICAL PORCELAIN.
2. GREY GLAZE MUNSELL 5BG 7.0/0.4
3. TOLERANCE $\pm 3\%$ WITH NOTHING LESS THAN $\pm .03"$.

SPECIFICATIONS:

1. RATED VOLTAGE.....18kV
2. BASIC IMPULSE LEVEL.....150kV
3. NOMINAL CURRENT RATING.....75 AMPS @ 1000A/SQ.-IN.
4. STRIKE DISTANCE.....10.40" [264.19mm]
5. CREEP DISTANCE(MIN).....20.21" [511.05mm]
6. APPROXIMATE WEIGHT.....9.1 LBS

THIRD ANGLE PROJECTION 	TOLERANCES (EXCEPT AS NOTED) DIMENSIONS ARE SHOWN IN: in/mm		H-J ENTERPRISES, INC. 3010 HIGH RIDGE BLVD. HIGH RIDGE, MO. 63049 USA PHONE 1-636-677-3421 FAX 1-636-376-1915	
	DECIMAL \pm		18kV 150kV BIL HV BUSHING ASSEMBLY	
PROPRIETARY AND CONFIDENTIAL THE INFORMATION CONTAINED IN THIS DRAWING IS THE SOLE PROPERTY OF H-J ENTERPRISES, INC. ANY REPRODUCTION IN PART OR AS A WHOLE WITHOUT THE WRITTEN PERMISSION OF H-J ENTERPRISES, INC. IS PROHIBITED.		FRACTIONAL \pm	MATERIAL (SEE DRAWING)	
REMOVE ALL BURRS & SHARP EDGES		ANGULAR $\pm 2^\circ$	CHK'D - APP'D - SCALE N.T.S.	DRAWING NO. AS1151-040
		DRAWN BY CJT	DATE 1-25-08	